

Mediant™ 500 E-SBC

Enterprise Session Border Controller

High-Availability System

Hardware Installation Manual



Version 6.8

June 2014

Document #: LTRT-10385



Table of Contents

1	Introduction.....	9
2	Unpacking the Device	11
3	Physical Description	13
3.1	Physical Dimensions	13
3.2	Front Panel Description	13
3.2.1	Ports and Buttons.....	13
3.2.2	LED Descriptions	14
3.2.2.1	Operational Status LED.....	14
3.2.2.2	LAN Interface LED.....	15
3.2.2.3	E1/T1 LEDs	15
3.2.2.4	Power LED.....	15
3.3	Rear Panel Description	16
4	Mounting the Device	17
4.1	Desktop Mounting	17
4.2	19-Inch Rack Mounting	18
4.2.1	Using a Pre-installed Rack Shelf	18
4.2.2	Using Mounting Brackets	19
5	Cabling the Device	21
5.1	Grounding the Device.....	21
5.2	Connecting to the LAN	22
5.3	Connecting to an ISDN PRI (E1/T1) Trunk	23
5.4	Connecting the Serial Interface to a PC	24
5.5	Connecting a USB Storage Device	25
5.6	Connecting to the Power Supply	26

List of Figures

Figure 3-1: Front Panel	13
Figure 3-2: Rear Panel	16
Figure 4-1: Location for Applying Rubber Feet.....	17
Figure 4-2: Left Mounting Bracket	19
Figure 4-3: Right Mounting Bracket.....	19
Figure 4-4: Attaching the Mounting Brackets	20
Figure 5-1: Earthing the Device	21
Figure 5-2: Cabling the LAN Ports.....	22
Figure 5-3: RJ-48c Connector Pinouts for E1/T1	23
Figure 5-4: Cabling E1/T1 Port	23
Figure 5-5: RS-232 Cable Adapter	24
Figure 5-6: Cabling Serial Port	24
Figure 5-7: Connecting a USB Storage Device	25
Figure 5-8: Connecting to the Power Supply	26

List of Tables

Table 3-1: Physical Dimensions	13
Table 3-2: Front Panel Description	14
Table 3-3: STATUS LED Description	14
Table 3-4: LAN LED Description.....	15
Table 3-5: E1/T1 LED Description.....	15
Table 3-6: POWER LED Description	15
Table 3-7: Rear Panel Description.....	16
Table 5-1: RJ-45 Connector Pinouts for GbE	22
Table 5-2: DB-9 to RJ-45 Serial Cable Connector Pinouts	24
Table 5-3: Power Specifications	26

This page is intentionally left blank.

Notice

This Hardware Installation Manual describes the hardware installation of AudioCodes **Mediant 500 Enterprise Session Border Controller (E-SBC)**.

Information contained in this document is believed to be accurate and reliable at the time of printing. However, due to ongoing product improvements and revisions, AudioCodes cannot guarantee accuracy of printed material after the Date Published nor can it accept responsibility for errors or omissions.

Before consulting this document, check the corresponding Release Notes regarding feature preconditions and/or specific support in this release. In cases where there are discrepancies between this document and the Release Notes, the information in the Release Notes supersedes that in this document. Updates to this document and other documents as well as software files can be downloaded by registered customers at <http://www.audiocodes.com/downloads>.

© Copyright 2014 AudioCodes Ltd. All rights reserved.

This document is subject to change without notice.

Date Published: June-29-2014

Trademarks

AudioCodes, AC, AudioCoded, Ardito, CTI2, CTI², CTI Squared, HD VoIP, HD VoIP Sounds Better, InTouch, IPmedia, Mediant, MediaPack, NetCoder, Netrake, Nuera, Open Solutions Network, OSN, Stretto, TrunkPack, VMAS, VoicePacketizer, VoIPerfect, VoIPerfectHD, What's Inside Matters, Your Gateway To VoIP and 3GX are trademarks or registered trademarks of AudioCodes Limited. All other products or trademarks are property of their respective owners.

WEEE EU Directive

Pursuant to the WEEE EU Directive, electronic and electrical waste must not be disposed of with unsorted waste. Please contact your local recycling authority for disposal of this product.

Customer Support

Customer technical support and services are provided by AudioCodes or by an authorized AudioCodes Service Partner. For more information on how to buy technical support for AudioCodes products and for contact information, please visit our Web site at www.audiocodes.com/support.

Abbreviations and Terminology

Each abbreviation, unless widely used, is spelled out in full when first used.

Throughout this manual, unless otherwise specified, the term *device* refers to Mediant 500 E-SBC.

Documentation Feedback

AudioCodes continually strives to produce high quality documentation. If you have any comments (suggestions or errors) regarding this document, please fill out the Documentation Feedback form on our Web site at <http://www.audiocodes.com/downloads>. Your valuable feedback is highly appreciated.

Related Documentation

Document Name
SIP Release Notes
Mediant 500 E-SBC User's Manual
CLI Reference Guide

General Notes



Note: Open source software may have been added and/or amended for this product. For further information, please visit our website at <http://audiocodes.com/support> or contact your AudioCodes sales representative.

Warnings and Safety Information



Warning: The device is an **INDOOR** unit and thus, must be installed only indoors. In addition, Ethernet port interface cabling must be routed only indoors and must not exit the building.



Caution Electrical Shock

Do not open or disassemble this device. The device carries high voltage and contact with internal components may expose you to electrical shock and bodily harm.



Warning: The device must be installed and serviced only by qualified service personnel.



Warning: For deployment in Finland, Sweden and Norway, the device must be installed **only** in restricted access locations that are compliant with ETS 300253 guidelines where equipotential bonding has been implemented.



Warning: Disconnect the device from the mains and Telephone Network Voltage (TNV) before servicing.

1 Introduction

This document provides a hardware description of the Mediant 500 E-SBC (hereafter referred to as *device*) and step-by-step procedures for mounting and cabling the device.

The device supports the following interfaces:

- Four Gigabit Ethernet (10/100/1000Base-T) LAN ports
- Single E1/T1 port interface over a single copper wire pair (PRI interface is a customer-ordered item)
- Two USB ports for optional, USB storage services
- Serial console port (RJ-45) for device management

**Notes:**

- Hardware configurations may change without notice. Currently available hardware configurations are listed in AudioCodes Price Book. For further enquiries, please contact your AudioCodes sales representative.
- For information on configuring the device, refer to the device's *User's Manual*.

This page is intentionally left blank.

2 Unpacking the Device

Follow the procedure below for unpacking the carton in which the device was shipped.

➤ **To unpack the device:**

1. Open the carton and carefully remove packing materials.
2. Remove the chassis from the carton.
3. Check that there is no equipment damage.
4. Ensure that in addition to the chassis, the package contains the following items:
 - Four anti-slide bumpers for desktop installation
 - Two mounting brackets for 19-inch rack mounting
 - Serial cable adapter
 - One AC power cable
5. Check, retain and process any documents.

If there are any damaged or missing items, notify your AudioCodes sales representative.

This page is intentionally left blank.

3 Physical Description

This section provides a physical description of the device.

3.1 Physical Dimensions

The device's physical dimensions and weight are listed in the table below:

Table 3-1: Physical Dimensions

Physical Specification	Value
Dimensions (H x W x D)	4.37 (1U) x 31.0 cm x 21.0 cm (1.72 x 12.2 x 8.3 in.)
Weight	2.0 kg (4.4 lbs.)
Environmental	<ul style="list-style-type: none"> ▪ Operational: 5 to 40°C (41 to 104°F) ▪ Storage: -25 to 85°C (-13 to 185°F) ▪ Humidity: 10 to 90% non-condensing

3.2 Front Panel Description

This section describes the device's front panel.

3.2.1 Ports and Buttons

The device's front panel is shown in the figure below and described in the subsequent table.

Figure 3-1: Front Panel



Table 3-2: Front Panel Description

Item #	Label	Description
1	POWER / STATUS	LEDs indicating the status of the power and reboot/initialization. For more information, see Section 3.2.2 on page 14.
2	//	Reset pinhole button for resetting the device and optionally, for restoring the device to factory defaults. To restore the device to factory defaults, do the following: With a paper clip or any other similar pointed object, press and hold down the pinhole button for at least 12 seconds, but no longer than 25 seconds
3	CONSOLE	RJ-45 port for RS-232 serial communication
4	LAN	Up to four Gigabit Ethernet (10/100/1000Base-T) ports for connecting to LAN network (IP phones, computers, or switches). These ports support half- and full-duplex modes, auto-negotiation, and straight or crossover cable detection.
5	PRI	Single E1/T1 port interface (RJ-48). Note: PRI interface is a customer-ordered item.
6	USB	Two USB 2.0 ports, which can be used, for example, for various storage capabilities using an external USB hard drive or flash disk (disk on key).

3.2.2 LED Descriptions

This section describes the LEDs provided on the front panel.

3.2.2.1 Operational Status LED

The **STATUS** LED indicates the operating status, as described in the table below.

Table 3-3: STATUS LED Description

LED Color	LED State	Description
Green	On	Device is operational.
	Flashing	Initial rebooting stage.
Red	On	Boot failure.
-	Off	Advanced rebooting stage.

3.2.2.2 LAN Interface LED

Each Ethernet port provides a LED for indicating LAN operating status, as described in the table below.

Table 3-4: LAN LED Description

LED Color	LED State	Description
Green	On	Ethernet link established.
	Flashing	Data is being received or transmitted.
-	Off	No Ethernet link.

3.2.2.3 E1/T1 LEDs

The E1/T1 trunk port provides a LED for indicating operating status, as described in the table below:

Table 3-5: E1/T1 LED Description

Color	State	Description
Green	On	Trunk is synchronized (normal operation).
Red	On	Loss due to any of the following signals: <ul style="list-style-type: none"> ▪ LOS - Loss of Signal ▪ LOF - Loss of Frame ▪ AIS - Alarm Indication Signal (the Blue Alarm) ▪ RAI - Remote Alarm Indication (the Yellow Alarm)
-	Off	Failure / disruption in the AC power supply or the power is currently not being supplied to the device through the AC power supply entry.

3.2.2.4 Power LED

The **POWER** LED indicates the power supply status, as described in the table below.

Table 3-6: POWER LED Description

LED Color	LED State	Description
Green	On	Power is received by the device.
-	Off	No power received by the device.

3.3 Rear Panel Description

The device's rear panel is shown in the figure below and described in the subsequent table.

Figure 3-2: Rear Panel

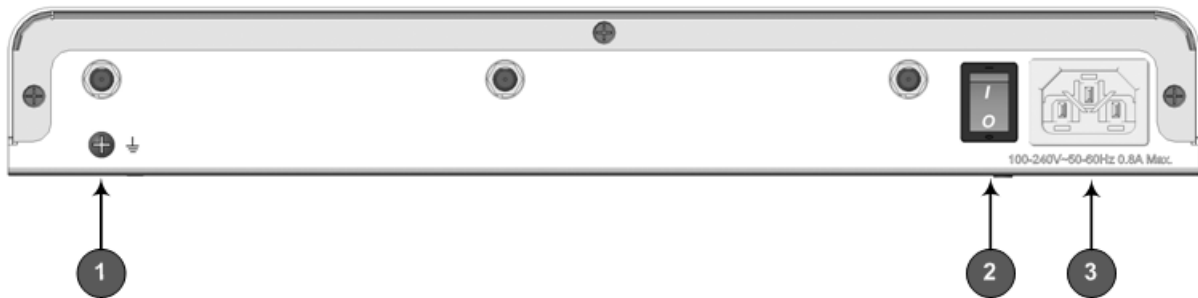



Table 3-7: Rear Panel Description

Item #	Label	Description
1		Protective earthing screw.
2	I / O	Power switch (O is off; I is on).
3	100-240V~50-60Hz 0.8A Max.	Three-prong AC power supply entry.

4 Mounting the Device

The device can be mounted in one of the following ways:

- Placed on a desktop – see Section 4.1 on page 17
- Installed in a standard 19-inch rack – see Section 4.2 on page 18



Warning: Do not place any equipment directly on top of the device or adjacent to its sides (at least 13-cm separation). In addition, if you are mounting the device in a 19-inch rack, ensure that at least a 3U separation is maintained between the device and other mounted devices or equipment.

4.1 Desktop Mounting

The device can be placed on a desktop when its four anti-slide bumpers (supplied) are attached to the underside of the device.

➤ **To attach the anti-slide rubber bumpers to the device:**

1. Flip the device over so that its underside faces up.
2. Locate the four anti-slide grooves on the underside - one in each corner.
3. Peel off the adhesive, anti-slide rubber feet and stick one in each anti-slide groove.

Figure 4-1: Location for Applying Rubber Feet

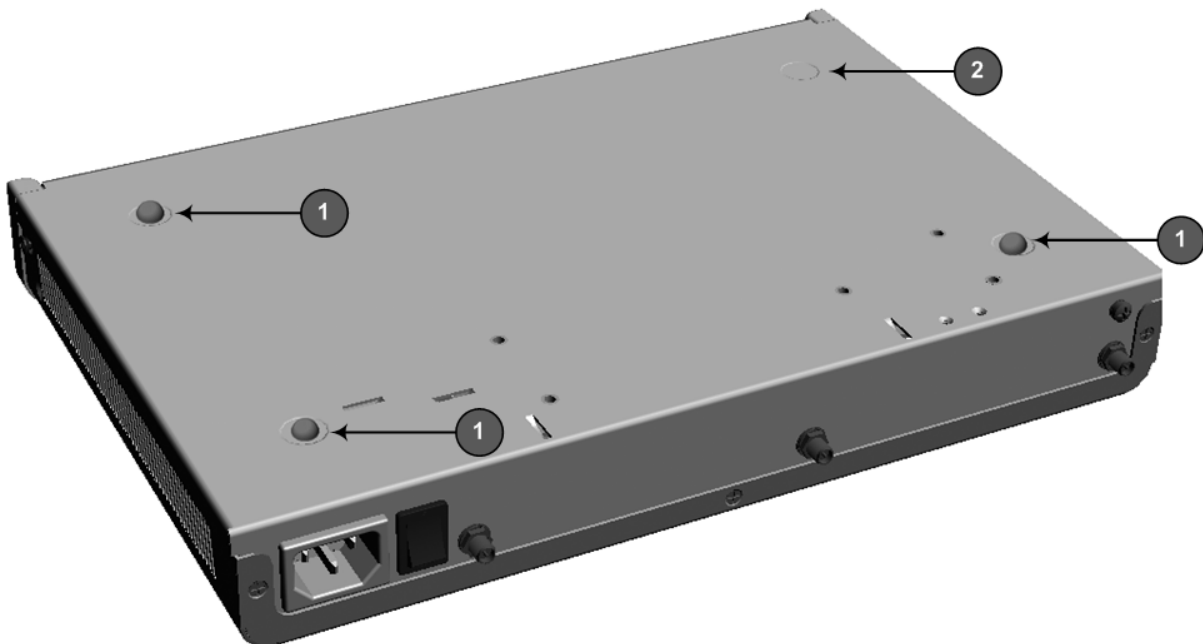

- 1 = Mounted anti-slide rubber feet
 - 2 = Anti-slide groove
4. Flip the device over again so that it rests on the rubber feet and place it in the required position on a desktop.

4.2 19-Inch Rack Mounting

The device can be installed in a standard 19-inch rack by implementing one of the following mounting methods:

- Placing it on a pre-installed shelf in a 19-inch rack – see Section 4.2.1 on page 18
- Attaching it directly to the rack's frame using the device's mounting brackets (supplied) that need to be attached to the chassis – see Section 4.2.2 on page 19



Rack Mount Safety Instructions

When installing the chassis in a rack, implement the following safety instructions:

- **Elevated Operating Ambient Temperature:** If installed in a closed or multi-unit rack assembly, the operating ambient temperature of the rack environment may be greater than room ambient temperature. Therefore, consideration should be given to installing the equipment in an environment with maximum ambient temperature (T_{ma}) of 40°C (104°F).
- **Reduced Air Flow:** Installation of the equipment in a rack should be such that the amount of air flow required for safe operation on the equipment is not compromised.
- **Mechanical Loading:** Mounting of the equipment in the rack should be such that a hazardous condition is not achieved due to uneven mechanical loading.
- **Circuit Overloading:** Consideration should be given to the connection of the equipment to the supply circuit and the effect that overloading of the circuits might have on over-current protection and supply wiring. Appropriate consideration of equipment nameplate ratings should be used when addressing this concern.
- **Reliable Earthing:** Reliable earthing of rack-mounted equipment should be maintained. Particular attention should be given to supply connections other than direct connections to the branch circuit (e.g., use of power strips). For earthing the device, see Section 5.1 on page 21.

4.2.1 Using a Pre-installed Rack Shelf

The procedure below describes how to place the device on a pre-installed shelf in a 19-inch rack.

- **To mount the device on a pre-installed shelf in the rack:**
 1. Before installing it in the rack, ensure that you have a pre-installed rack shelf on which the device can be placed.
 2. Place the device on the pre-installed shelf in the rack.

4.2.2 Using Mounting Brackets

The procedure below describes how to mount the device in a 19-inch rack. Rack mounting involves placing the device on a pre-installed rack shelf and then attaching the device's mounting brackets to the device and rack frame. The purpose of the mounting brackets is to secure the device to the rack.

Two mounting brackets are provided:

- Left mounting bracket:

Figure 4-2: Left Mounting Bracket

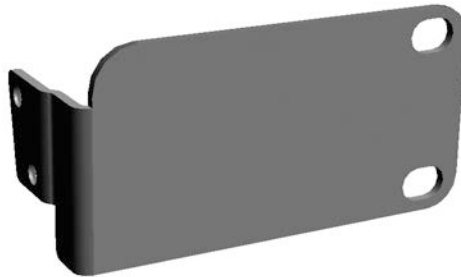

- Right mounting bracket with hole for looping through an optional cable tie (not supplied) for securing cables:

Figure 4-3: Right Mounting Bracket

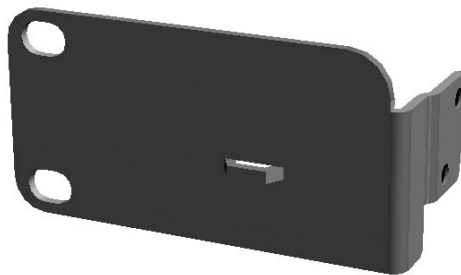

➤ **To mount the device in a 19-inch rack using mounting brackets:**

1. Attach the two mounting brackets (supplied) to each side of the device's chassis, using the supplied screws, as shown in the figure below:

Figure 4-4: Attaching the Mounting Brackets

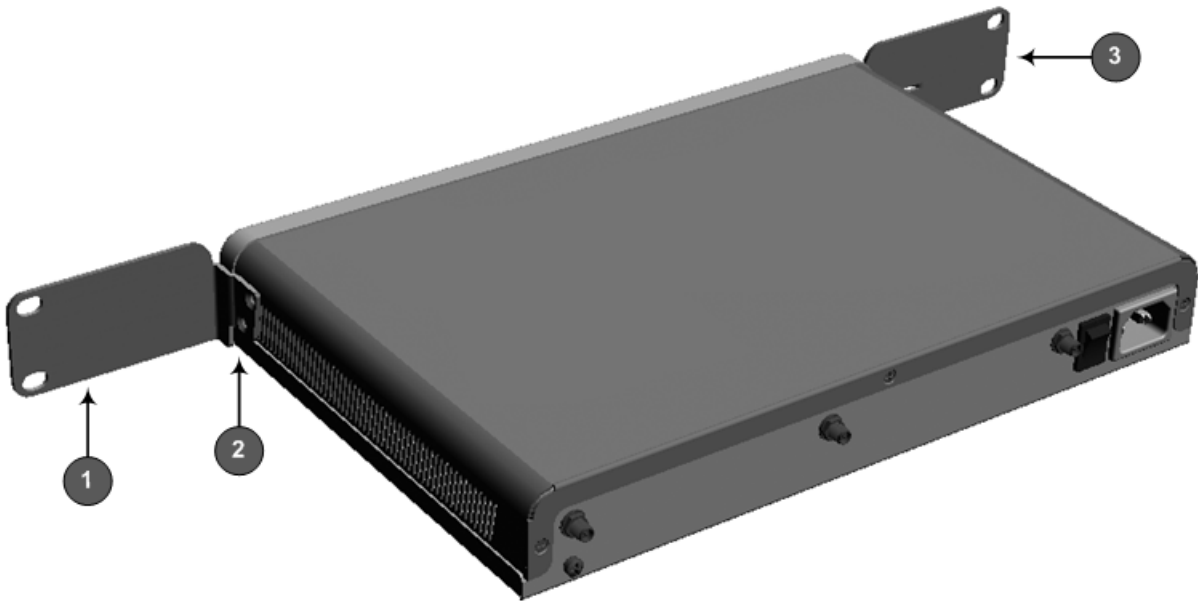

- 1 = Left mounting bracket
 - 2 = Attached screws
 - 3 = Right mounting bracket
2. Place the device on a pre-installed shelf in the rack.
 3. Attach the ends of the mounting brackets (that you installed in Step 1) to the vertical track of the rack's frame, using standard 19-inch rack bolts (not supplied).

5 Cabling the Device

This section describes the cabling of the device, which includes the following:

- Grounding (earthing) the device – see Section 5.1 on page 21
- Connecting to the LAN – see Section 5.2 on page 22
- Connecting to an E1/T1 trunk – see Section 5.3 on page 23
- Connecting to a computer for serial communication – see Section 5.4 on page 24
- Connecting a USB storage device – see Section 5.5 on page 23
- Connecting to the power supply – see Section 5.6 on page 26

5.1 Grounding the Device

The device must be connected to earth (grounded) using an equipment-earthing conductor.



Protective Earthing

The equipment is classified as Class I EN60950 and UL60950 and must be earthed at all times.

For Finland: "Laite on liltettava suojamaadoituskoskettimilla varustettuun pistorasiaan."

For Norway: "Apparatet må tilkoples jordet stikkontakt."

For Sweden: "Apparaten skall anslutas till jordat uttag."

➤ To earth the device:

1. Connect an electrically earthed strap of 16 AWG wire (minimum) to the chassis' earthing screw (located on the rear panel), using the supplied washer.
2. Connect the other end of the strap to a protective earthing. This should be in accordance with the regulations enforced in the country of installation.

Figure 5-1: Earthing the Device

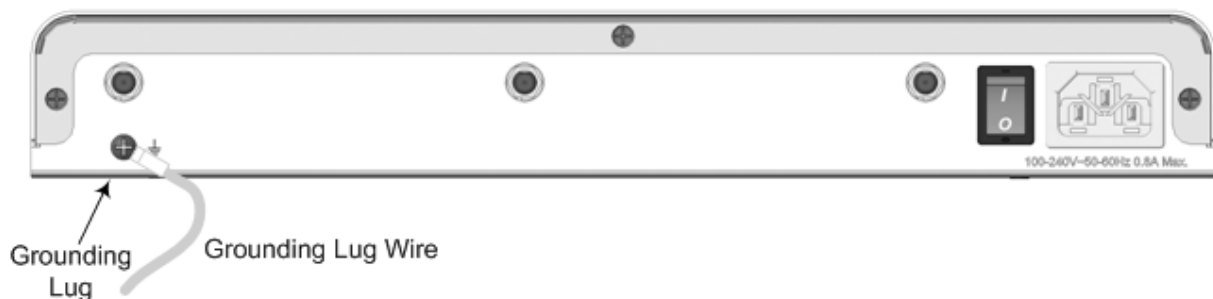

5.2 Connecting to the LAN

The device provides up to four Gigabit Ethernet (10/100/1000Base-T) ports for connection to the LAN (e.g., computers, switches, and IP phones). These ports support half- and full-duplex modes, auto-negotiation, and straight or crossover cable detection.

The RJ-45 connector pinouts are described in the table below:

Table 5-1: RJ-45 Connector Pinouts for GbE

Pin	Signal Name
1	Ethernet signal pair (10/100/1000Base-T)
2	
3	Ethernet signal pair (10/100/1000Base-T)
6	
4	Ethernet signal pair (1000Base-T)
5	
7	Ethernet signal pair (1000Base-T)
8	
Shield	Chassis ground

➤ **To connect the device to the LAN:**

1. Connect one end of a straight-through RJ-45 Cat 5e or Cat 6 cable to the RJ-45 port labeled **S1 / LAN GE**.

Figure 5-2: Cabling the LAN Ports

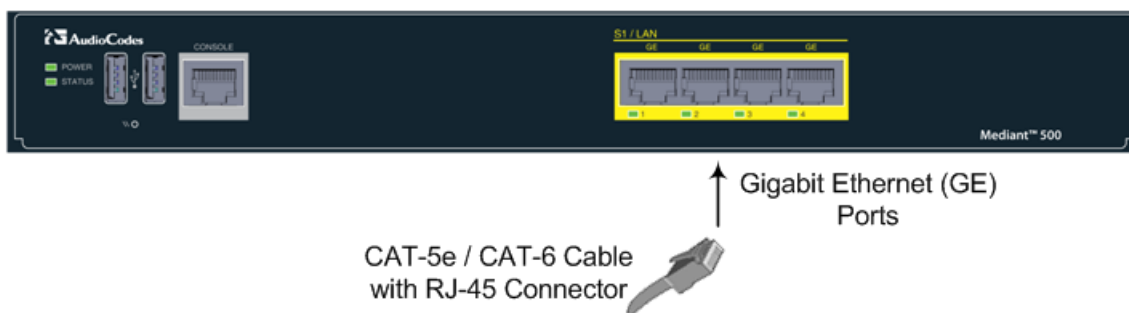

2. Connect the other end of the cable to the Gigabit Ethernet network.

5.3 Connecting to an ISDN PRI (E1/T1) Trunk

The procedure below describes the cabling of the device's E1/T1 (PRI) trunk interface.



Warning: To protect against electrical shock and fire, use a 26 AWG min wire to connect the E1 / T1 port to the PSTN.



Note: PRI interface is a customer-ordered item.

The RJ-48c trunk connector used in the cabling is wired according to the figure below:

Figure 5-3: RJ-48c Connector Pinouts for E1/T1

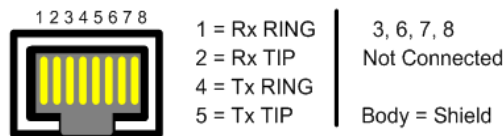

➤ **To connect the E1/T1 trunk interface:**

1. Connect the E1/T1 trunk cable to the device's E1/T1 port.
2. Connect the other end of the trunk cable to your PBX/PSTN switch.

Figure 5-4: Cabling E1/T1 Port



5.4 Connecting the Serial Interface to a PC

The device provides an RS-232 serial interface port on its front panel. The serial cable adapter used for connecting the RS-232 interface is shown below:

Figure 5-5: RS-232 Cable Adapter

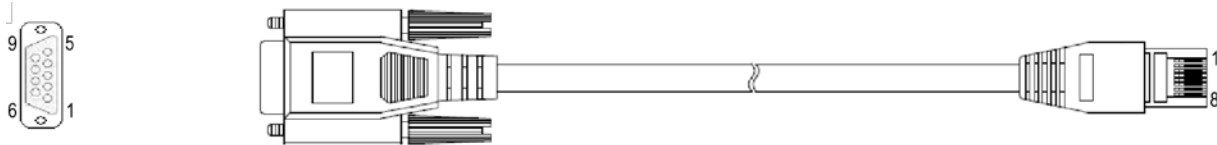

Table 5-2: DB-9 to RJ-45 Serial Cable Connector Pinouts

DB-9 Female	RJ-45
8	1
6	2
2	3
5	4
5	5
3	6
4	7
7	8

➤ **To connect the device's serial interface port to a PC:**

1. Connect the end of the cable providing the RJ-45 connector to the device's serial port located on the front panel, labeled **CONSOLE**.

Figure 5-6: Cabling Serial Port

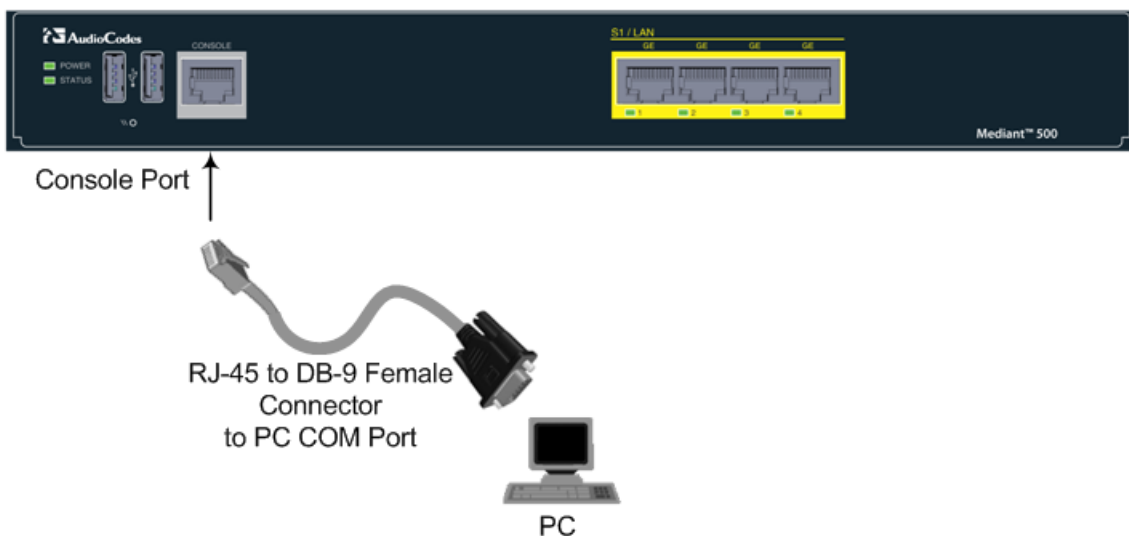

2. Connect the other end of the cable providing the 9-pin DB connector to the COM RS-232 communication port on your computer.

5.5 Connecting a USB Storage Device

The device supports USB storage capabilities, using an external USB hard drive or flash disk (disk on key) connected to the device's USB port. The storage capabilities are configured through CLI and include the following:

- Saving network captures to the USB
 - Updating the device's firmware from the USB
 - Updating the device's configuration from the USB
 - Saving the current configuration to the USB
- **To connect the USB storage device:**
- Connect the USB storage device to one of the USB ports located on the front panel.

Figure 5-7: Connecting a USB Storage Device

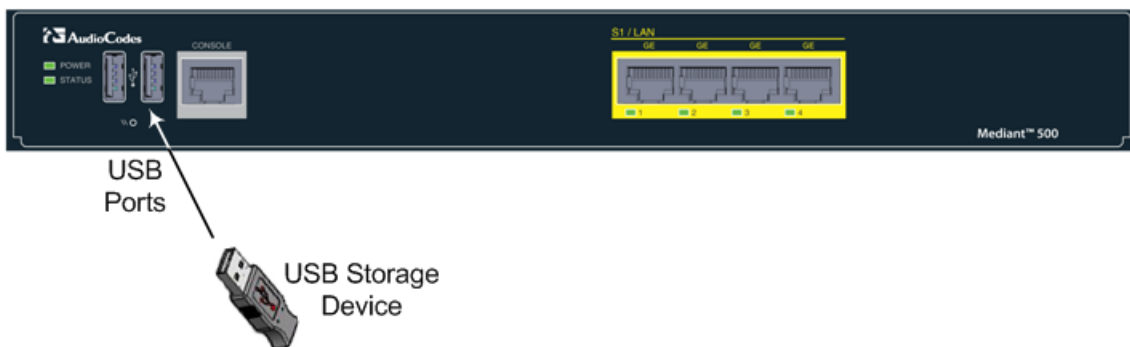

Note: Only a single USB storage (formatted to FAT/FAT32) operation is supported at any given time.

5.6 Connecting to the Power Supply

The device receives power from a standard alternating current (AC) electrical outlet. The connection is made using the supplied AC power cord.

Table 5-3: Power Specifications

Physical Specification	Value
Input Voltage	Single universal AC power supply 100 to 240V
AC Input Frequency	50 to 60 Hz
AC Input Current	0.8A



Warnings:

- The device must be connected to a socket-outlet providing a protective earthing connection.
- Use only the AC power cord that is supplied with the device.

➤ **To connect the device to the power supply:**

1. Connect the line socket of the AC power cord (supplied) to the device's AC power socket (labeled **100-240V~50-60 Hz 0.8A**), located on the rear panel.

Figure 5-8: Connecting to the Power Supply



2. Connect the plug at the other end of the AC power cord to a standard electrical outlet.
3. Press the power switch to on (I) position so that the device receives power; the **POWER** LED on the front panel is lit green (for more information, see Section 3.2.2.4 on page 15).

This page is intentionally left blank.



Hardware Installation Manual



www.audiocodes.com